

## MECHANICAL DISCHARGE DEVICE VIBRATING CAGE

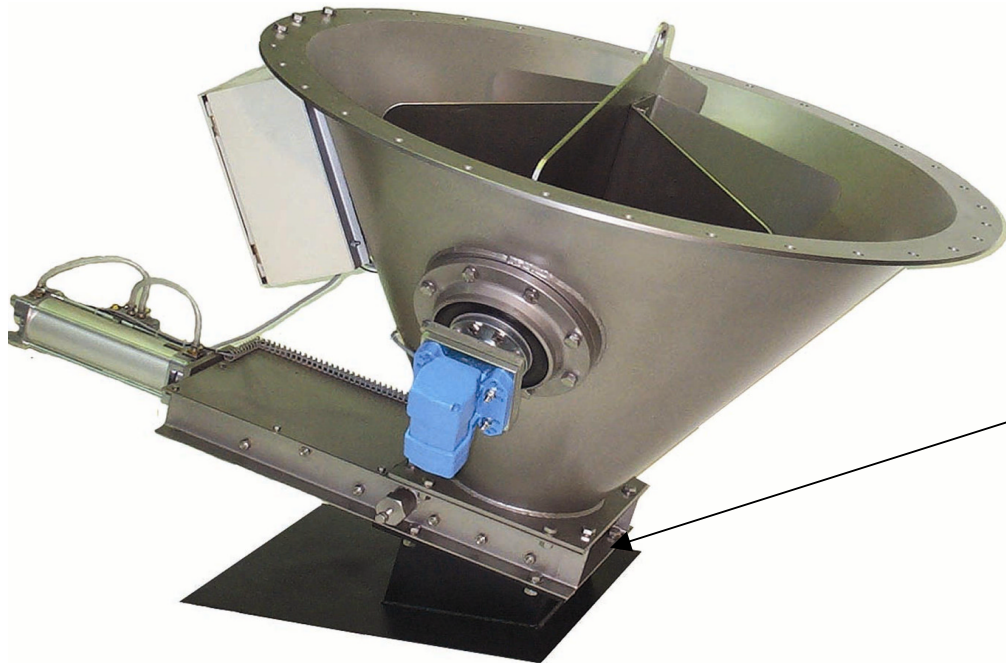

Gate valve optional

The Stanelle vibrating cage serves as discharge aid for all lazy flowing and bridge-building, dry, dusty to granulated bulk materials. Major advantage over air operated systems is that the discharged bulk materials do not contain fluidizing air. This has positive effects during bagging as well as when loading silo vehicles. The flanged version with 60° outlet slope can easily be attached to any silo or bunker - even subsequent.

### Areas of Application

- Free of fluidizing air
- Simple installation and maintenance
- Compact construction, low abrasion, no overhanging parts
- Pressure surge protected up to 3 bar, Ex-proof (optional)
- Max. operating temperature 80° C.
- Heatable cone

### Details / Explanation

- Material grade: steel or stainless steel, top coat with hammer tone silver grey; various colors available on inquiry

### Finish

**Dimensions and technical Data**

Nominal diameter	Ø 1200	Ø 1500	Ø 1800
D1 ø	1200	1500	1800
D2 ø	1300	1600	1900
Number of holes x ø	32 x ø 18	36 x ø 18	40 x ø 18
D3 – ø, H	on customer inquiry		
Vibration engine	0,16 KW		
Voltage	400, 500, or 690 V		

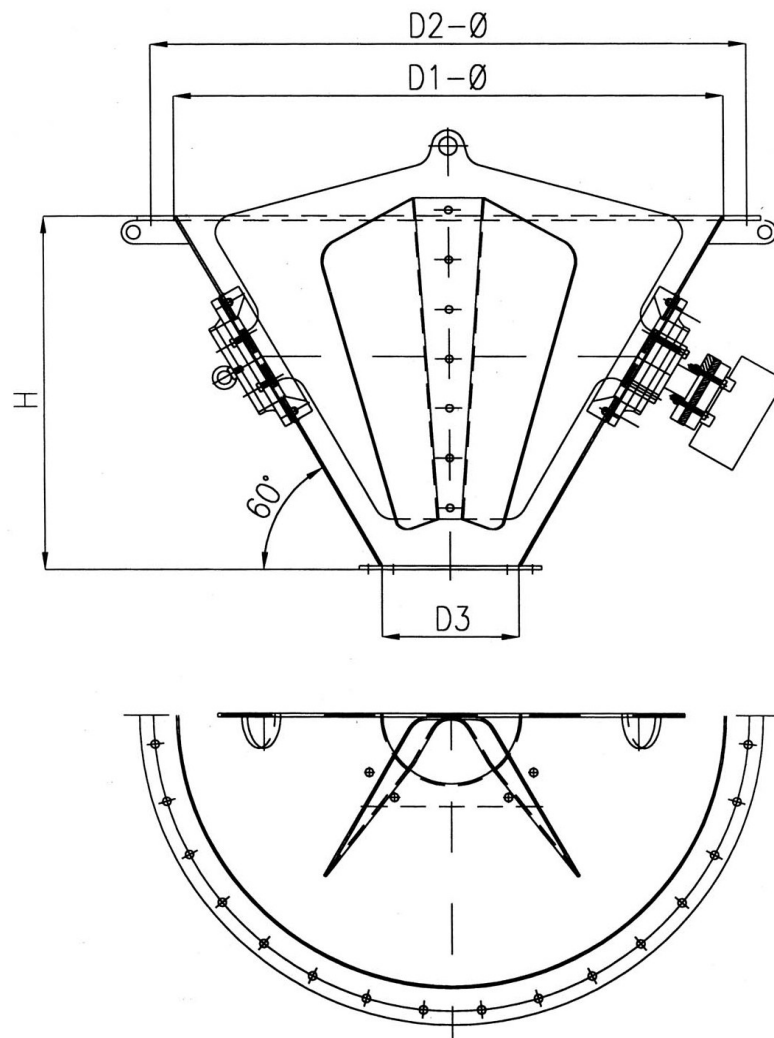

**Article Number**

Nominal diameter	Ø 1200		Ø 1500		Ø 1800	
	Steel	VA 1.4301	Steel	VA 1.4301	Steel	VA 1.4301
Article number	741 10 006	741 10 008	741 10 005	741 10 009	741 10 004	741 10 022

**Additional colors and options can be tailored to your special application!**

**Notice**

