

MINIMUM LEVEL SENSOR

UNIVERSAL VIBRATION LIMIT SWITCH FOR FINE GRAINED BULK MATERIALS.

**For dust explosion
imperiled areas on
application**



This vibration limit switch is a robust fill level sensor for silos with grained or dusty bulk materials, even if they have a very low piled weight. The different construction designs allow various areas of application, also in dangerous dust explosion areas of the zone 20 or in foodstuffs.

Areas of Application

Details / Explanation

- No compensation, fast and low-cost start of operation.
- Non-sensitive to crust building, maintenance-free operation.
- No mechanically moved parts, no abrasion, long durability.
- Various electronic applications, optimal adaptation into the system control.
- Body with clear cover, switching status display recognizable from outside, easy to control.
- Aluminum body with separated connection space, also for protection model EEx de
- Plastic, high-grade steel 1.4571 or aluminum.

Body Finish

Installation

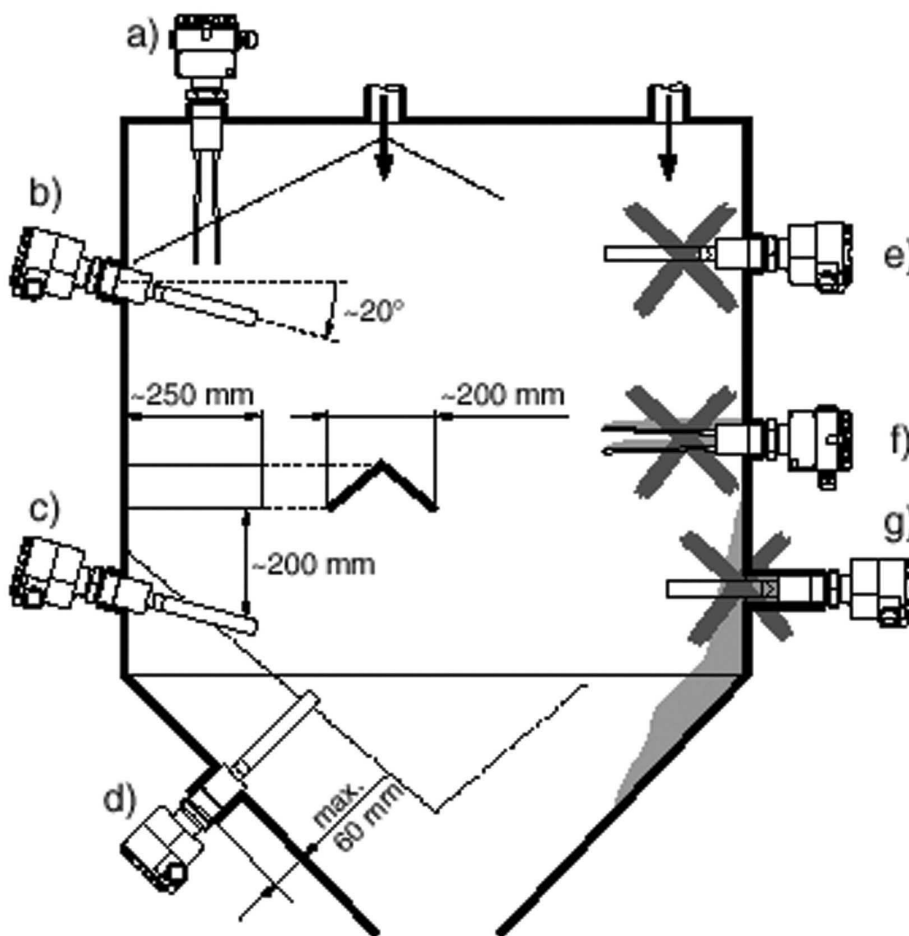

When calculating the necessary cord length, the angle of driving slope and the angle of repose or the haul-off hopper have to be considered.

See correct installation to the left side of the drawing:

- a) at a right angle from above; swing fork position arbitrary
- b) sideways, swing forks are slightly bend down so that bulk cargo can slip off easily
- c) With protection roof (length approx. 250 mm, width approx.200 mm) against collapsing overhangs.
- d) Max. socket length of 60 mm inside the hopper

See wrong installation to the right side of the drawing:

- e) directly in the stream of bulk material
- f) incorrect positioning of swing forks (high stress on the wide side of the swing forks through pressuring bulk material; malfunction due to congregation of bulk material)
- g) Too long screw-in socket

The symmetrical swing fork is stimulated on its resonance frequency. If it dives into bulk cargo, the swing character changes, and the electronic activates either an electronic switch or a relays. On top of the swing fork the vibrating limit switch is extremely sensitive which allows a minimum detection level in bulk materials with very low plied density. At the swing fork root however, the vibrating limit switch is non-sensitive, as a result crust building on the container wall does not influence the proper function. The vibrating limit switch can be operated in minimum or maximum standby current protection, which means when reaching the minimal or maximal fill level, filling errors or power failure the electronic switch locks up or the relay drops down.

Functioning

Scale drawing

Short construction,
with thread
R 1½ (DIN 2999)

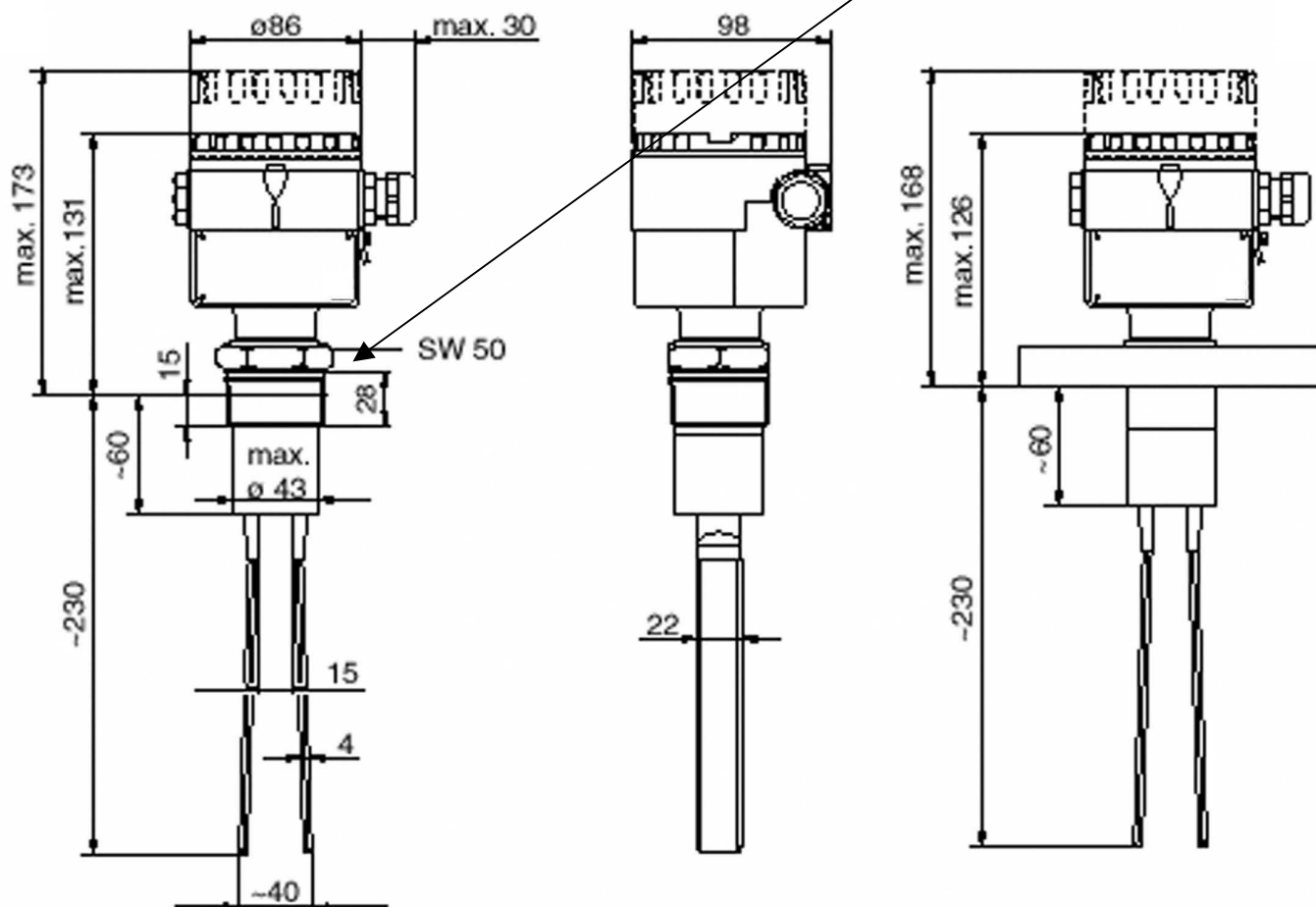

Technical Data

Vibration limit switch	
Functioning	Absorbing of the swinging of a self-resonance swinging oscillating fork.
System structure	Complete fill level limit switch, consisting of measuring type probe with pre-installed electronic application (switch gear).
Signal processing	Two-wire-alternating current specification. Switching the demand over a thyristor directly in the supply unit electric system. Three-wire-continuous current specification. Switching the demand over a transistor and a separate connection. All current specification with relay output. Switching the demand over a potential-free change-over contact.
Galvanic isolation	Between measuring sensor and emergency current
Measured variable, metering range	Filling level (threshold, binary), given through point of installation
Output signal	Binary; when reaching the threshold outlet blocked.
Safety switch	Minimum – or maximum – standby current security, switchable.
Response time	Ca.0,5 s at covering, ca.1,5 s at release. Switchable to ca. 2,5 s at covering, ca.7,5 s at release.
Precision of measurements at a temperature T =20 °C, operating pressure p =1 bar, piled density of the bulk material >1 kg/l, grain size <2 mm	Error of measurement: Ca.10 mm at vertical installation, 5mm at sideways installation of the probe. Settling time: After activating the emergency current the outlet keeps blocked for ca. 2,5 s. Response time variation: +/- 25 % at covering or release. Influences of temperature and operating pressure: insignificant.
Ambient temperature	-40 °C ...+70 °C
Type of protection (body)	IP 66 after DIN 40050
Temperature of measuring material	-40 °C ...+150 °C
Piled density of measuring material	min.20 g/l
Grain size of measuring material	up to 10 mm
Process connections	Conical thread R 1 ½ after DIN 2999 part 1.
Electronic connection	Screw clamps on the electronic application for maximum 2,5 mm² cord. In end splice A 2,5 -7 after DIN 46228. Screw clamps in a separate connection space for aluminum bodies with plastic coating. For max.2,5 mm² cord in end splice A 2,5 -7 after DIN 46228.
Operation display surface	Rotary switch for change-over of the minimum and maximum safety switching. Red illuminating diode for displaying the status.

Article number

Vibration limit switch	
	Article number
	731 10 083

MINIMUM LEVEL SENSOR

LOW COST VIBRATION LIMIT SWITCH FOR FINE GRAINED BULK MATERIALS.



Areas of Application

This vibration limit switch is a robust fill level sensor for silos with grained or dusty bulk materials, even if they have a very low piled weight. The different construction designs allow various areas of application e.g. foodstuffs.

- No compensation, fast and low-cost start of operation.
- Non-sensitive to crust building, maintenance-free operation.
- No mechanically moved parts, no abrasion, long durability.
- Various electronic applications, optimal adaptation into the system control.
- Body with clear cover, switching status display recognizable from outside, easy to control.

Details / Explanation

- Polyester.

Body Finish

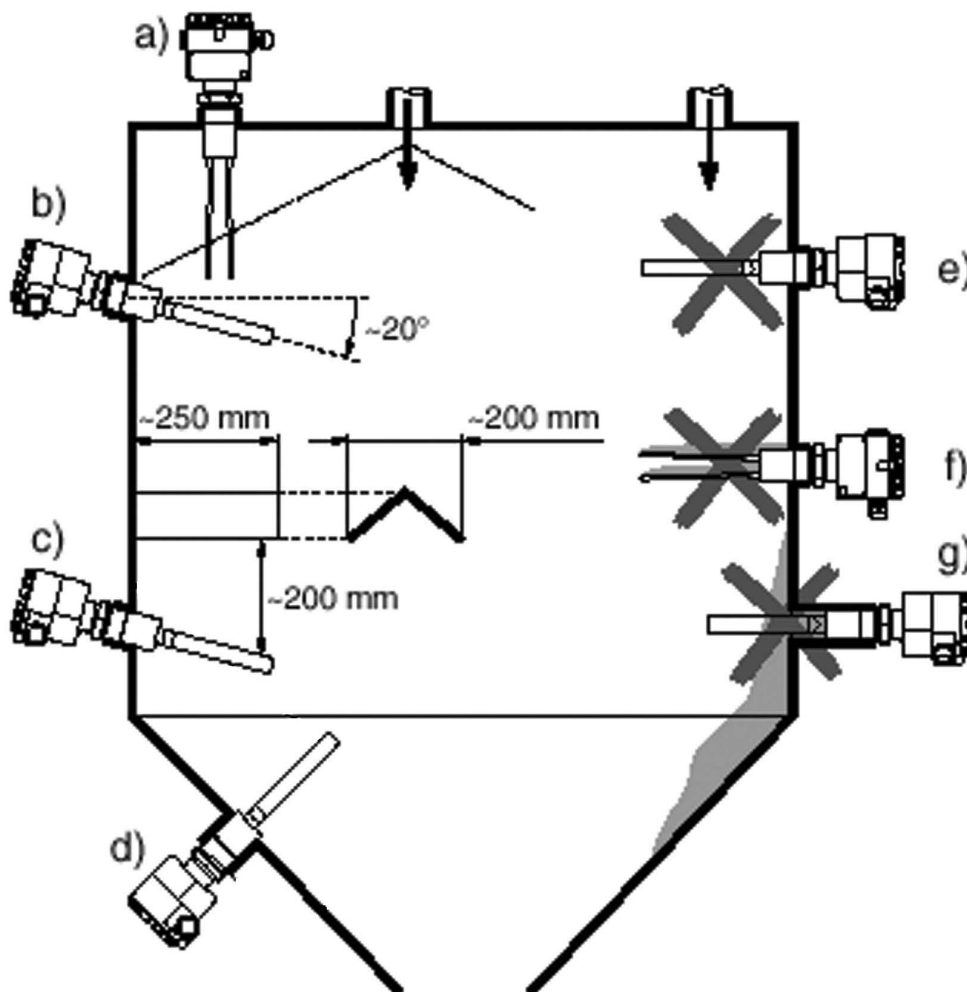

The vibration limit switch may be installed in any position according to the left side of the drawing.

See correct installation to the left side of the drawing:

- a) at a right angle from above; swing fork position arbitrary
- b) sideways, swing forks are slightly bend down so that bulk cargo can slip off easily
- c) With protection roof (length approx. 250 mm, width approx.200 mm) against collapsing overhangs.
- d) Max. socket length of 60 mm inside the hopper

See wrong installation to the right side of the drawing:

- e) directly in the stream of bulk material
- f) incorrect positioning of swing forks (high stress on the wide side of the swing forks through pressuring bulk material; malfunction due to congregation of bulk material)
- g) Too long screw-in socket

Functionality

The symmetrical swing fork is stimulated on its resonance frequency. If it dives into bulk cargo, the swing character changes, and the electronic activates either an electronic switch or a relays. On top of the swing fork the vibrating limit switch is extremely sensitive which allows a minimum detection level in bulk materials with very low plied density. At the swing fork root however, the vibrating limit switch is non-sensitive, as a result crust building on the container wall does not influence the proper function. The vibrating limit switch can be operated in minimum or maximum standby current protection, which means when reaching the minimal or maximal fill level, filling errors or power failure the electronic switch locks up or the relay drops down.

Scale drawing

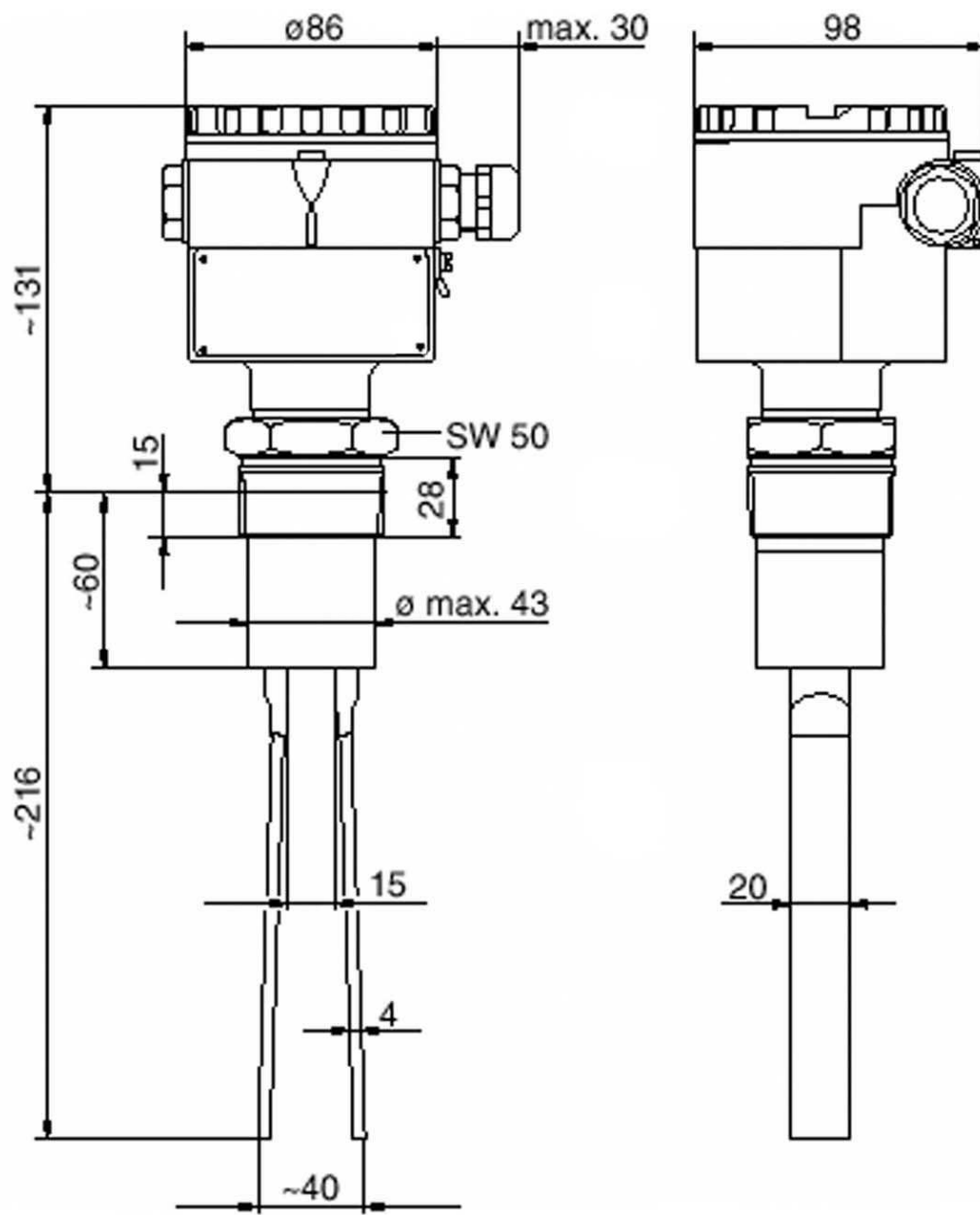

The clear cover allows a direct look at the light-emitting diode and the switch display

The plastic body, protection type IP 66, with various cable entry points.

Variants of process connection
 R 1½, DIN 2999,
 (conical)
 made of noncorrosive steel.

Swing fork made of massive non corrosive steel with high resistance to stress and pressure

Technical Data

Vibration limit switch	
Functioning	Vibration limit switch binary
System structure	Compact unit, electronic application pluggable
Signal processing	<p>Two-wire-alternating current specification, always connect in series!</p> <p>Pay attention to fall of voltage at the electronic application when connect through design applies (up to 12 V), the residual current in locked up mode (up to 3,8 mA) and low connection voltage resulting in fall of voltage above the working resistance so that the tension does not fall below the minimum disk tension in the electronic application (19 V).</p> <p>Three-wire-continuous current specification, preferred in connection with stored-program controls (SPS). Positive signal at the relay switching output of the electronic application.(PNP)</p> <p>All current specification with relay output. Switching the demand over a potential-free change-over contact.</p>
Safety switch	Minimum – or maximum – standby current security, switchable.
Response time	Ca.0,6 s at covering, ca.1,4 s at release.
Ambient temperature	-40 °C ...+70 °C
Type of protection (body)	IP 66 after DIN 40050
Temperature of measuring material	-40 °C ...+150 °C
Operating pressure	1 bar...+16 bar (burst pressure > 40 bar)
Piled density of measuring material	min.100 g/l
Grain size of measuring material	up to 10 mm
Process connections	Conical thread R 1 ½ after DIN 2999 part 1.
Electronic connection	Screw clamps on the electronic application for maximum 2,5 mm ² cord in In end splice A 2,5 - 7 after DIN 46228.
Operation display surface	Illuminating diode for displaying the status

Article number

Vibration limit switch	
	Article number
	731 10 100

MINIMUM LEVEL SENSOR

CAPACITIVE LIMIT LEVEL DETECTION COMPACT FILLING LEVEL LIMIT SENSOR WITH INTEGRATED ACTIVE OUTLET COMPENSATION.

For dust explosion
imperiled areas on
application



This filling level sensor is used for limit level detection in light bulk materials, e.g. crop, wheat, milk powder, mixed feed, cement, chalk or hard plaster.

Areas of Application

- Easy installation; you can start operating without calibration because unit exists of sensor and electric application
 - Integrated, active beginning compensation, thereby exact switching point also at heavy crust building on the sensor and high operational safety
 - No abrasion, long durability, maintenance-free.
 - Various electronic applications, optimal adjustment to the system control.
 - With pole sensor 140 mm.
-
- Polyester, IP 66

Details / Explanation

Body Finish

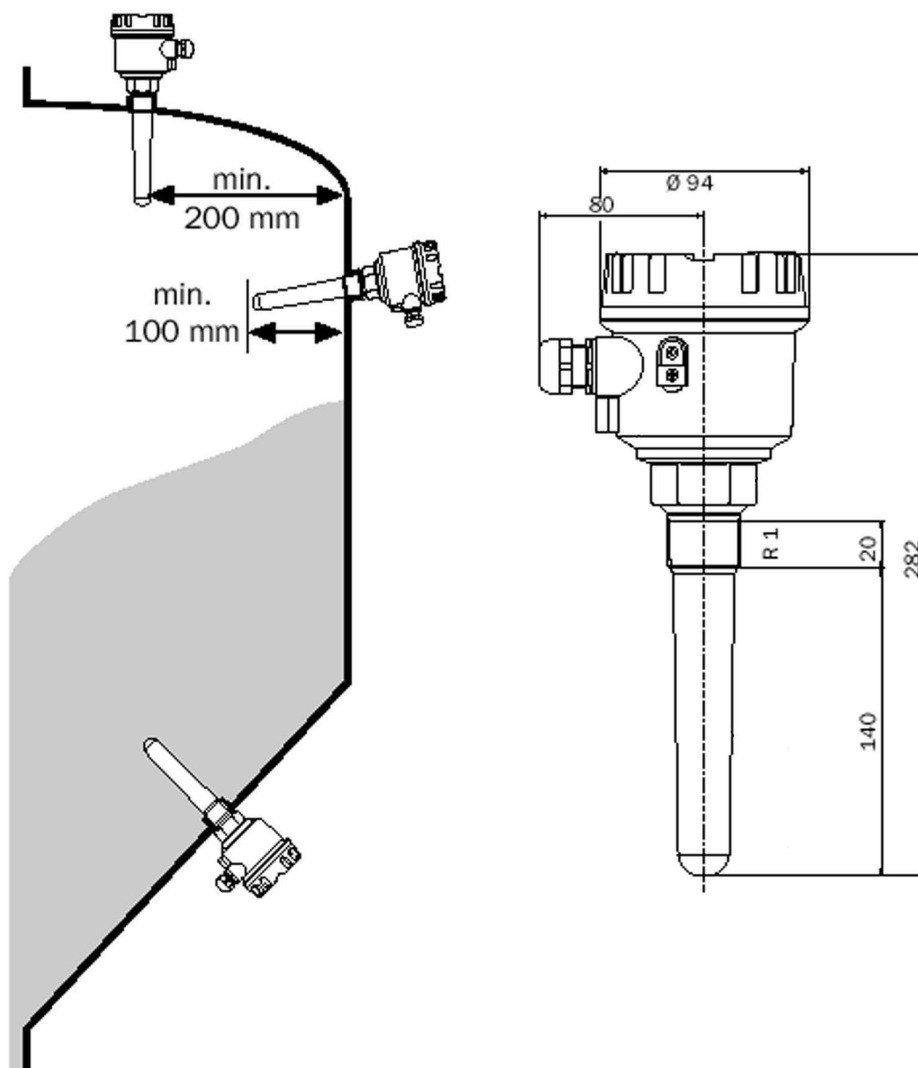

**Installation / Scale
 Drawing**

When deciding for an installation position the angle of driving slope of the angle of repose or the haul-off hopper have to be considered

The limit level detection is used within silos with bulk materials. The silos can be made of various materials (e.g. metal, plastic, concrete), because this does not affect the metering process.

This filling level limit switch is an electronic switch. When over or under filling the limit level a switch signal displays. A control device or various signals (lamps, horns, PLS, SPS, etc.) can be directly connected to the filling level sensor. The sensor possesses a built in switch for minimum/maximum level security. The sensor recognises crust building and compensates its influence so that the switching level always remains the same. The correct execution of the beginning compensation is dependent on the thickness of the crust on the sensor as well as the conductivity of the sensor pad and the sensitivity settings made electronically. The filling level sensor is factory-made calibrated and delivered. The device can be calibrated with various sensitivity settings. In order to operate safe and error-free, the filling level sensor has to be connected to a grounded silo with a metal or ferro concrete wall. When using silos made of insulating materials, the ground has to be connected to a conductive and grounded alternative nearby. A standard installation cable can be used as a connector.

Functionality

Technical Data

Capacitive filling level limit detection	
Functioning	Capacitive
System structure	Compact device with sensor on rope, binary signal transmission.
Metering range	$\epsilon_r \geq 1,6$
Electronic application	With continuous current PNP-transistor exit, with continuous current/ alternating current relay output.
Output signal	Switch PNP: I_{max} 200 mA, overload / short-circuit protection, residual voltage on the transistor at $I_{max} < 2,9$ V. Contact change switch, potential-free: $U_{\sim max}$ 253 V, $I_{\sim max}$ 4 A $P_{\sim max}$ 1000 VA, $\cos \phi = 1$ $P_{\sim max}$ 500 VA, $\cos \phi > 0,7$ $I_{_ max}$ 4 A, bis $U_{_}$ 30 V $I_{_ max}$ 0,2 A, bis $U_{_}$ 235 V
Response time	At covering or release 0,5 s
Precision of measurements (for plastic container) at: Temperature T 23 °C Measuring material temperature 23 °C Measuring pressure $p_e = 0$ bar. Measuring material: Relative permittivity $\epsilon_r = 2,6$ Conductivity $< 1 \mu S$, setting sensitivity switch: C	Hysteresis: Horizontal: 4 mm, Vertical: 7 mm Shift point: Horizontal: Middle of the sensor -5 mm, Vertical: 40 mm above sensor end Rising action: After max. 1,5 s correct shift setting Long-time drift: Horizontal: 3 mm, Vertical: 6 mm Influence of measuring temperature: Depending on the filling material
Ambient temperature	-40 °C ...+70 °C, (...+60 °C dust ex-version)
Type of protection (body)	IP 66
Measuring material temperature	0 °C ...+70 °C
Measuring material pressure limit	-1...+25 bar
Piled density of measuring material	min.200 g/l, $\epsilon_r \geq 1,6$
Grain size of measuring material	max. 30 mm
Process connection	Thread R 1 after DIN 2999 BSPT.
Electrical connection	Screw clamp connection: For cord max. 1,5 mm ² . For wire max. 2,5 mm ² .
Operating display surface	Switch on the electronic application: Shift between min.- and max. security. Adjustment of sensitivity (dependent from relative permittivity ϵ_r and crust building). Normally, an adjustment of sensitivity is not necessary.

Article number

Capacitive filling level limit detection	
	Article number
	731 10 101